

Instruction guide for RE201, RE202, RE203 series wall mount remotes

1. PRODUCT APPEARANCE

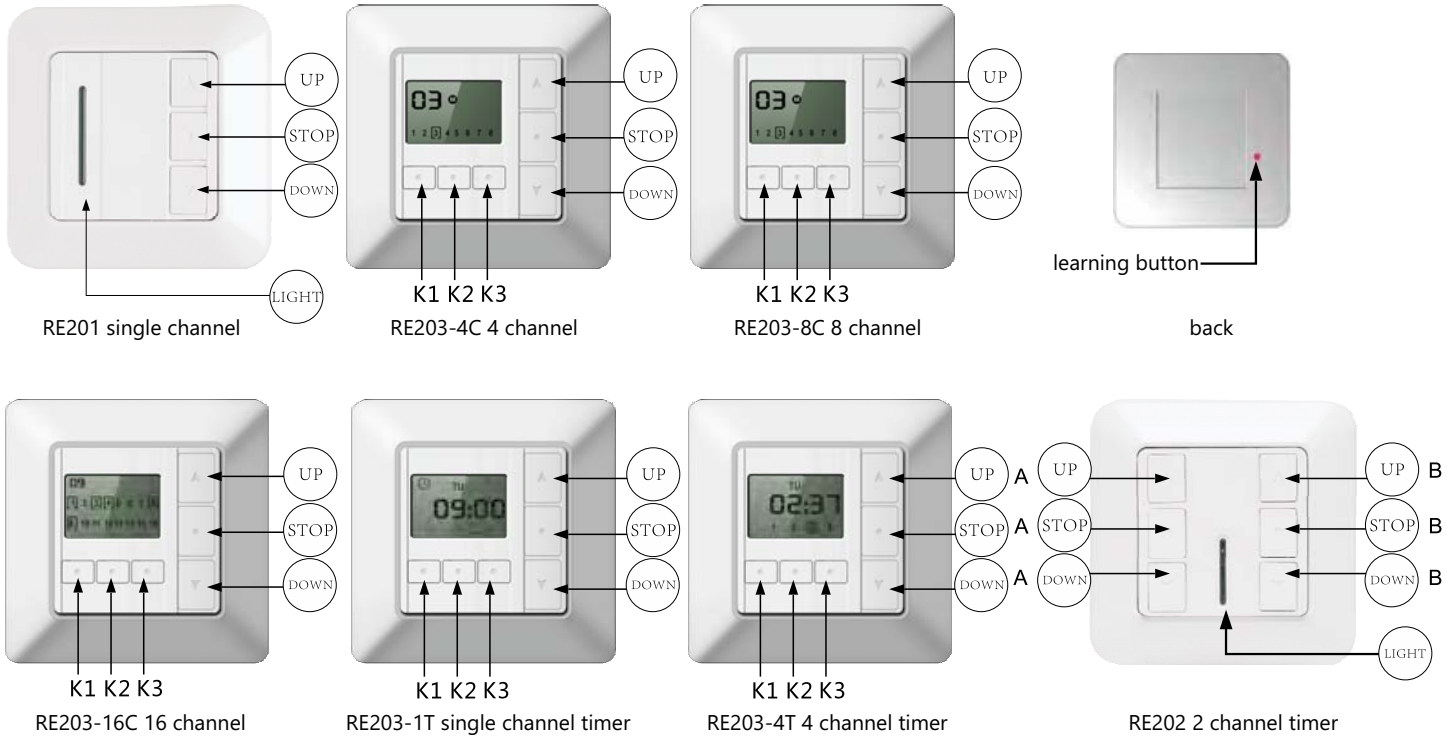

2. TECHNICAL DATA

- Power: 3V Model: CR2032
- Working Temperature: -10°C to +60°C (LCD remote)
- Working Temperature: -20°C to +60°C (Non- LCD remote)
- Current: ≤12mA
- Code: Rolling Code
- Frequency: 433.92MHz

1. wall mount
2. panel

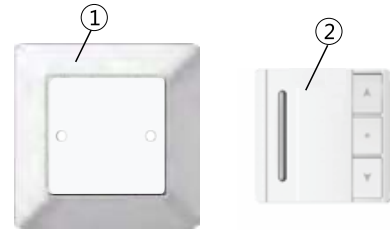

3. CODE LEARNING (Note: Please do not perform code learning in group control mode.)

01. single-channel

Short press the learning button on the back, the code learning is successful.

02. LCD multi-channel (take 8 channel remote as an example)

The figure on upper left corner of the screen shows the current channel. Short press K1/K3 to choose any channel from 1 to 8.

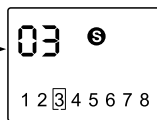

Choose one channel, short press the learning button on the back, now code learning is successful. Choose another channel to learn code in the same way.



learning button

03. Two channel remote: channel A & channel B control 2 receivers respectively without interference.

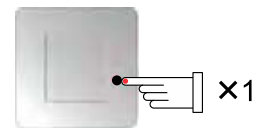
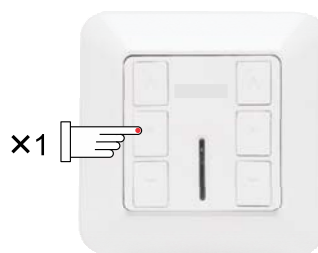
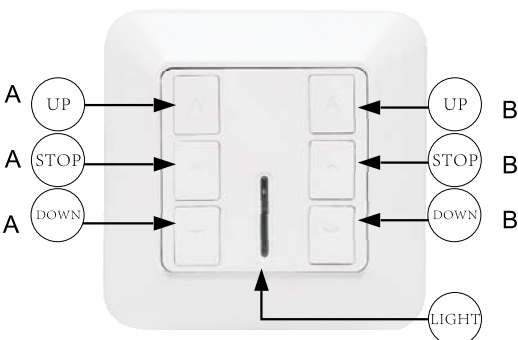

Short press STOP button of Channel A once, then Short press learning button (on the back) once within 10 seconds, code learning for channel A is successful. This method is suitable for Channel B code learning.

Instruction guide for RE201, RE202, RE203 series wall mount remotes

4. SINGLE CONTROL

Select a channel by pressing K1/K3 as the current channel, then you can control this channel by pressing a UP/STOP/DOWN button.

5. GROUP CONTROL (LCD) Short press K2 button to choose group control **M** or single control **S**

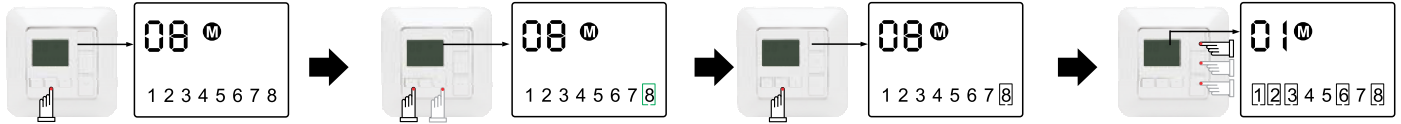

Long press K2 for 2s to enter Group Control, the current channel on the upper left corner of the screen will shine.

Short press K1/K3 to choose channels into your group, for example channel 8 as the picture shows.

Short press K2 to confirm, same method for other channels.

Press UP/STOP/DOWN buttons to exit the setting.

6. DELETE GROUP CONTROL

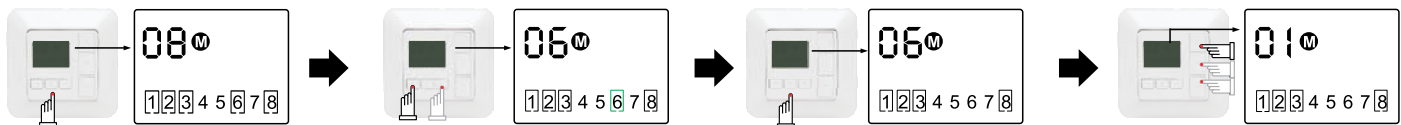

Long press K2 for 2s to enter Group Control state, the current channel on the upper left corner of the screen will shine.

Short press K1/K3 to choose channels out your group, for example channel 6 as the picture shows.

Short press K2 to confirm, same method for other channels.

Press UP/STOP/DOWN buttons to exit the setting.

Note: whether in **M** or **S** mode, the current channel is always selected.

7. LCD FOUR CHANNEL TIMER REMOTE

01. Time Setting

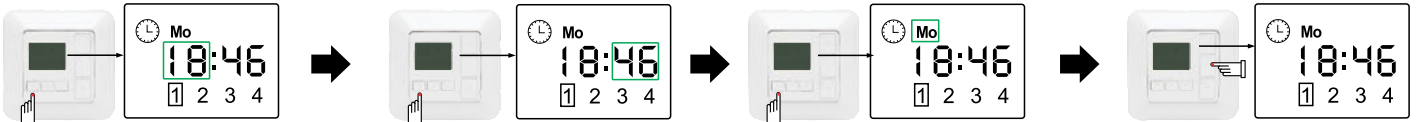

Press K1 button to enter hour setting page, now the hour figure will shine. Press UP/DOWN button to adjust the hour figure.

Once the hour setting is finished, press K1 again to adjust minute, the minute figure will shine. Press UP/DOWN button to adjust the figure.

Once the minute setting is finished, press K1 again to adjust weekday, the weekday figure will shine. Press UP/DOWN button to adjust the weekday.

After setting, press STOP button to exit and go back to the initial page.

02. Timing Setting (set different time points to make the motor close or open)

In the initial page, press K2 to enter timing setting page, there is a timing clock on the upper left corner.

You can respectively set 8 opening time points and 8 closing time points, in total 16 points. 1 ~ 8

Press K2 to cycle among 16 time points. Press K3 to choose the output channels which you want (single channel or 4 channels)

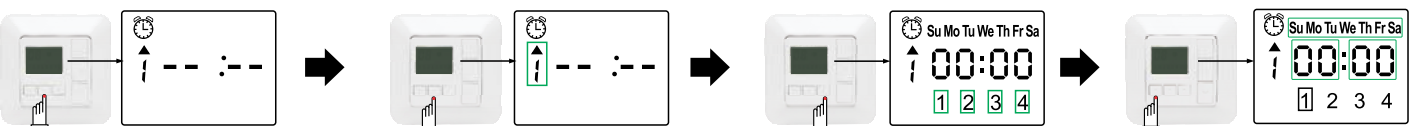

Press K2 to enter timing setting page.

Press K2 again to select one point among 16 timing points.

Press K3 to choose your wanted channel (single channel or 4 channels).

Press K1 to set time (in the same way of Time Setting above).

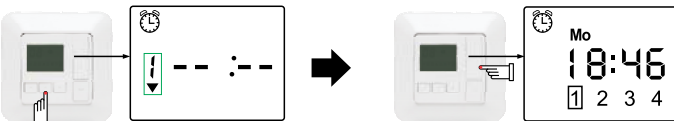

After one time point is set, press K2 again to select other time points to set time.

Press STOP button to exit the setting.

03. Close Timing Function

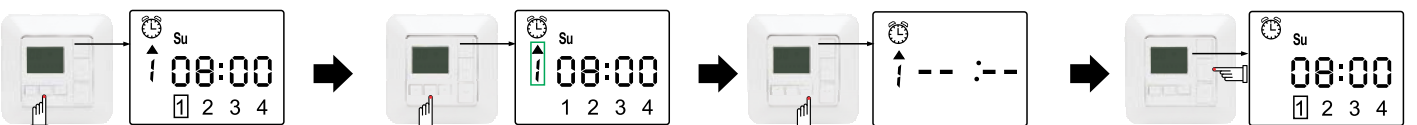

Press K2 to enter timing setting page.

Press K2 again to select one point that needs to be closed.

Press K3 until above display appears, which means the point has closed. Press K3 again to retrieve this point.

After setting, press STOP button to exit and go back to the initial page.

Instruction guide for RE201, RE202, RE203 series wall mount remotes

8. LCD TIMER REMOTE (1 CHANNEL)

01. Time Setting

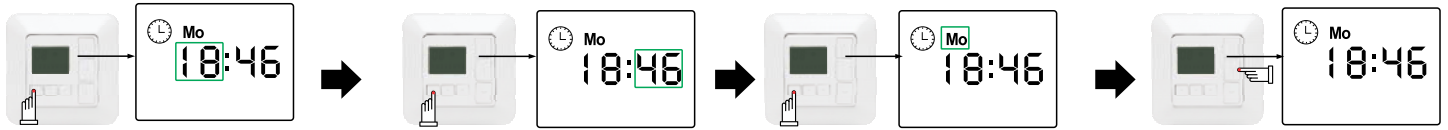

Press K1 button to enter hour setting page, now the hour figure will shine. Press UP/DOWN button to adjust hour figure.

Once the hour setting is finished, press K1 again to adjust minute, the minute figure will shine. Press UP/DOWN button to adjust minute figure.

Once the minute setting is finished, press K1 again to adjust weekday, the weekday figure will shine. Press UP/DOWN button to adjust weekday.

After setting, press STOP button to exit and go back to the initial page.

02. Timing Setting

In the initial page, press K2 to enter timing setting page, there is a timing clock on the upper left corner. You can respectively set 8 opening time points and 8 closing time points, in total 16 points. 1~8 Press K2 to cycle among 16 time points.

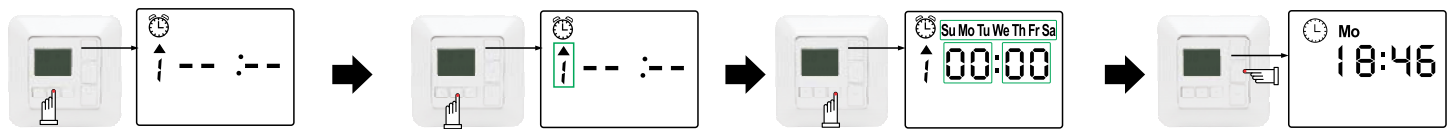

Press K2 to enter timing setting page.

Press K2 again to select one point among 16 timing points.

Press K3 to enter time setting page, then press K1 to set the time points in the same way as above time setting.

Once one time point is set, press K2 again to select other time points to set time. When setting finished, press STOP to exit.

03. Close Timing Function

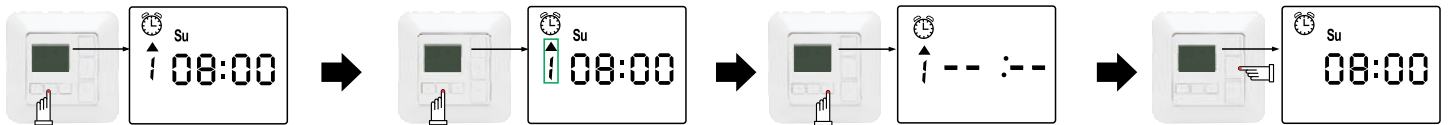

Press K2 to enter timing setting page.

Press K2 again to select one point that needs to be closed.

Press K3 once to delete the point. Press K3 again to retrieve this point.

After setting, press STOP button to exit and go back to the initial page.

04. Stop Watch Function

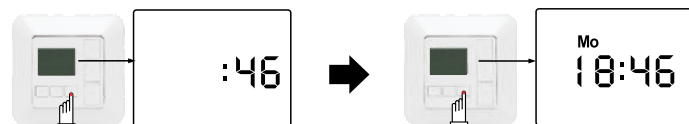

In the initial page, press K3 to enter Stopwatch page.

If you want to exit from Stopwatch page, press K3 again to go back to the initial page.

Note:

1. The remote must enter timing setting page if you want to set timing points. There should be a timing clock on the upper left corner, otherwise, the setting is invalid. If there is no clock on the screen, please hold STOP button and press K2 within 10 seconds, there will be a clock on the upper left corner.
2. It is better not to press the remote's buttons too long so as to prolong the battery's life. The button press should be about 0.5s with 1s interval.
3. The remote will stop working if the battery is in low power. Please replace the battery.